

Snippets of Physics

2. Angular Momentum of Electromagnetic Field*

T Padmanabhan



T Padmanabhan works at IUCAA, Pune and is interested in all areas of theoretical physics, especially those which have something to do with gravity.

Electromagnetic fields carry not only energy and momentum but also angular momentum. The angular momentum of the field can lead to some curious results like the one which is described here.

You would have certainly learnt that the electromagnetic field possesses energy and momentum. The usual expressions for energy per unit volume (U) and momentum per unit volume (\mathbf{P}) are

$$U = \frac{1}{8\pi}(E^2 + B^2); \quad \mathbf{P} = \frac{1}{4\pi c}(\mathbf{E} \times \mathbf{B}) \quad (1)$$

For example, the expression for energy density is used in elementary courses to study the energy stored in a capacitor or in a solenoid, while the expression for electromagnetic momentum is required to study the radiation pressure of the electromagnetic waves and related phenomena.

What is not stressed adequately in textbooks is that the electromagnetic fields – and pretty simple ones at that – also possess angular momentum. Just as the electromagnetic field can exchange its energy and momentum with charged particles, it can also exchange its angular momentum with a system of charged particles, often leading to rather surprising results. In this installment, we shall explore one such example.

A simple configuration in which exchange of angular momentum occurs is shown in *Figure 1*, discussed in Volume II of *Feynman lectures in Physics* [1]. A plastic disk, located in the x - y plane, is free to rotate about the vertical z -axis. On the disk is embedded a thin metallic

* This is based on an article originally published by the author in *Physics Education*, Vol. 23, No.4, p.285, 2006.

Keywords

Angular momentum, electromagnetic field, magnetic flux, solenoid, momentum density.



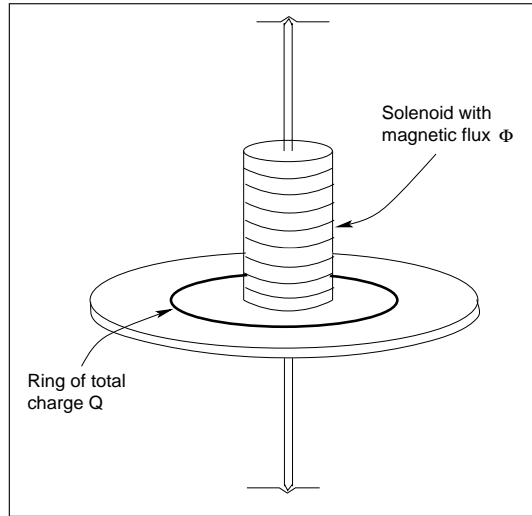

Figure 1. The initial configuration of solenoid and a plastic disk.

ring of radius a carrying a uniformly distributed charge Q . Along the z -axis, there is a thin long current-carrying solenoid producing a magnetic field \mathbf{B} contributing a total flux Φ . This initial configuration is completely static with a magnetic field \mathbf{B} confined within the solenoid and an electric field \mathbf{E} produced by the charge located on the ring. Let us suppose that the current source is disconnected leading the magnetic field to die down. The change in the magnetic flux will lead to an electric field which will act tangential to the ring of charge thereby giving it a torque. Once the magnetic field dies down, this torque will result in the disk spinning about the z -axis with a finite angular momentum. The question is where does this angular momentum come from?

Feynman presents a detailed discussion about this problem but it is obvious that the angular momentum in the initial field is what appears as the mechanical angular momentum of the rotating disk in the final stage. What is really important and interesting is to work this out and explicitly verify that the angular momentum is conserved (which Feynman unfortunately doesn't do!). I will describe this calculation as well as some interesting issues which arise from it in this installment[2].

The question is where does this angular momentum come from?



The angular momentum in the initial field is related to the mechanical angular momentum in the final stage.

The angular momentum of the final rotating disk is easy to compute. The rate of change of angular momentum $d\mathbf{L}/dt$ due to the torque acting on the ring of charge is along the z -axis and so we only need to compute its magnitude. This is given by

$$\frac{dL}{dt} = aQE = \frac{Q}{2\pi} \oint \mathbf{E} \cdot d\mathbf{l} = -\frac{Q}{2\pi c} \frac{\partial \Phi}{\partial t}. \quad (2)$$

Here \mathbf{E} is the tangential electric field generated due to the changing magnetic field and the last equality follows from Faraday's law. Integrating this equation and noting that the initial angular momentum of the disk and the final magnetic flux are zero, we get

$$L = \frac{Q}{2\pi c} \Phi_{\text{initial}}. \quad (3)$$

It is interesting that the final angular momentum depends only on the total flux and not on other configurational details.

We now need to show that the initial static electromagnetic configuration had this much of stored angular momentum. I will first do this in a rather unconventional manner and then indicate the connection with the more familiar approach. To do this, let us recall that the canonical momentum of a charge q located in a magnetic field is given by $\mathbf{p} - (q/c)\mathbf{A}$, where \mathbf{A} is the vector potential related to the magnetic field by $\mathbf{B} = \nabla \times \mathbf{A}$ and \mathbf{p} is the usual kinematic momentum. This suggests that one can associate with charges located in a magnetic field, a momentum $(q/c)\mathbf{A}$. For a distribution of charge, with a charge density ρ , the field momentum per unit volume will be $(1/c)\rho\mathbf{A}$. Hence, to a charge distribution located in a region of vector potential \mathbf{A} , we can attribute an angular momentum

$$\mathbf{L}_A = \frac{1}{c} \int d^3\mathbf{x} \rho(\mathbf{x})[\mathbf{x} \times \mathbf{A}(\mathbf{x})]. \quad (4)$$



In our problem, the charge distribution is confined to a ring of radius a and there is negligible magnetic field in the location of the charge. But the vector potential will exist outside the solenoid and the above expression can be non-zero. To compute this, let us use a cylindrical coordinate system with (r, θ, z) as the coordinates. We will choose a gauge in which the vector potential has only the tangential component; that is, only A_θ is non-zero. Using

$$\oint \mathbf{A} \cdot d\mathbf{l} = \Phi, \tag{5}$$

where Φ is the total magnetic flux, we get $2\pi r A_\theta = \Phi$ for a line integral of A around any circle. Hence $A_\theta = \Phi/(2\pi r)$. This can be written in a nice vectorial form as

$$\mathbf{A} = \frac{\Phi}{2\pi r^2}(\hat{\mathbf{z}} \times \mathbf{r}), \tag{6}$$

where $\hat{\mathbf{z}}$ is the unit vector in the z-direction. When we substitute this expression in equation(4) and calculate the angular momentum, the integral gets contribution only from a circle of radius a . Using further the identity, $\mathbf{r} \times (\hat{\mathbf{z}} \times \mathbf{r}) = \hat{\mathbf{z}}r^2$, we get the result that

$$\mathbf{L}_A = \frac{Q}{2\pi c} \Phi_{\text{initial}}\hat{\mathbf{z}}, \tag{7}$$

which is exactly the final angular momentum that we computed in equation (3). Rather nice!

This elementary derivation, as well as the expression for electromagnetic angular momentum in equation (4) raises several intriguing issues. On the positive side, it makes vector potential a very tangible quantity, something which we learnt from relativity and quantum mechanics but could never be clearly demonstrated within the context of classical electromagnetism. In the process, it also gives a physical meaning to the field momentum $(q/c)\mathbf{A}$ which is somewhat mysterious in conventional approaches. On the flip side, one should note that \mathbf{A} , by

The derivation gives a physical meaning to the field momentum $(q/c)\mathbf{A}$ which is somewhat mysterious in conventional approaches.



We would like to have a definition of electromagnetic angular momentum which is gauge invariant.

the very definition, is gauge dependent and one would have preferred a definition of electromagnetic angular momentum which is properly gauge invariant.

It is, of course, possible to write down another expression for the electromagnetic angular momentum which is more conventional. Given the density of electromagnetic momentum, \mathbf{P} , we can define the corresponding angular momentum density as $\mathbf{x} \times \mathbf{P}$. Integrating it over all space should give the angular momentum associated with the electromagnetic field. Since the momentum density \mathbf{P} involves only the electric and magnetic fields, the resulting expressions are automatically gauge invariant. This leads to a definition of angular momentum given by

$$\mathbf{L}_{EM} = \frac{1}{4\pi c} \int d^3x [\mathbf{x} \times (\mathbf{E} \times \mathbf{B})], \quad (8)$$

which just replaces the momentum density $\rho\mathbf{A}/c$ in equation (4) by $(\mathbf{E} \times \mathbf{B}/4\pi c)$. It is trivial to verify that, as momentum densities, these two expressions are unequal in general. But what is relevant, as far as our computation goes, is the integral over the whole space of these two expressions. If these two expressions differ by terms which vanish when integrated over whole space, then we have an equivalent gauge invariant definition of field angular momentum.

It turns out that this is indeed the case in any static configuration if we choose to describe the magnetic field in a gauge which satisfies $\nabla \cdot \mathbf{A} = 0$. One can then show that

$$\frac{1}{4\pi} (\mathbf{E} \times \mathbf{B})^\alpha = \frac{1}{4\pi} (\mathbf{E} \times (\nabla \times \mathbf{A}))^\alpha = \rho A^\alpha + \frac{\partial V^{\beta\alpha}}{\partial x^\beta}, \quad (9)$$

where $V^{\beta\alpha}$ is a complicated second rank tensor built out of field variables. We are using the convention that repeated Greek indices (like β in the above last term of the above expression) are summed over 1,2,3. While



one can provide a proof of equation (9) using vector identities (you should try it out!), it is a lot faster and neater to use four-dimensional notation and special relativity to get this result. Such a derivation is outlined in the appendix for those who are familiar with the four-dimensional notation. Given the result in (9), it is easy to see that in our example we will get the same result irrespective of whether we use \mathbf{L}_A or \mathbf{L}_{EM} . This is because, when we integrate the expressions in (9) over all space, the term involving $V^{\beta\alpha}$ can be converted to a surface term at infinity which does not contribute.

Appendix

Let me briefly outline the derivation of (9) for those who are familiar with the four-dimensional notation. We begin with the expression for the momentum density of the electromagnetic field in terms of the stress tensor T^{ab} of the electromagnetic field (with the convention that Latin letters range over 0,1,2,3). To simplify the expressions we will also use the notation $\partial_i \equiv (\partial/\partial x^i)$, etc. The T^{00} component of this tensor is proportional to the energy density of the electromagnetic field, while the $T^{0\alpha}$ is proportional to the momentum density P^α . More precisely,

$$T_0^\alpha = \frac{1}{4\pi}(\mathbf{E} \times \mathbf{B})^\alpha = cP^\alpha. \quad (10)$$

On the other hand, the electromagnetic stress tensor can be written in terms of the four-dimensional field tensor F^{ab} in the form $T_0^\alpha = -(1/4\pi)F^{\alpha\beta}F_{0\beta}$. We will manipulate this expression using the facts that (i) the configuration is static and (ii) the vector potential satisfies the gauge condition $\nabla \cdot \mathbf{A} = \partial_\alpha A^\alpha = 0$, to prove (9).

Using the definition of the field tensor in terms of the four-vector potential, $F_{ij} = \partial_i A_j - \partial_j A_i$, we can write



Suggested Reading

- [1] RPFeynman, RB Leighton and MSands, *Feynman Lectures in Physics*, Narosa Publishing House, New Delhi, Vol.II, Section 17-4, 1986.
- [2] There is large literature on this problem not all of which is illuminating; one good place to start the search, J M Aguirregabiria and A Hernandez, *Eur.J.Phys.*, Vol.2, p.168, 1981.

$$\begin{aligned}
 T_0^\alpha &= -\frac{1}{4\pi}F^{\alpha\beta}F_{0\beta} = -\frac{1}{4\pi}(\partial^\alpha A^\beta - \partial^\beta A^\alpha)F_{0\beta}, \\
 &= -\frac{1}{4\pi}(\partial^\alpha A^\beta)F_{0\beta} + \frac{1}{4\pi}\partial^\beta(F_{0\beta}A^\alpha) - A^\alpha\frac{\partial^\beta F_{0\beta}}{4\pi}, \\
 &= -\frac{1}{4\pi}(-\partial^\alpha A^\beta\partial_\beta A_0) + \frac{1}{4\pi}\partial^\beta(F_{0\beta}A^\alpha) - A^\alpha\frac{\partial^\beta F_{0\beta}}{4\pi}.
 \end{aligned}
 \tag{11}$$

To arrive at the second line we have done an integration by parts and to obtain the third line we have used $\partial_0 A_\beta = 0$ since the configuration is time independent. We next use the result $\partial^\beta F_{0\beta} = -\nabla \cdot \mathbf{E} = -4\pi\rho$ in the last term and another integration by parts in the first term, using the gauge condition $\nabla \cdot \mathbf{A} = \partial_\alpha A^\alpha = 0$. This gives

$$T_0^\alpha = \rho A^\alpha + \frac{1}{4\pi}\partial_\beta[A_0\partial^\alpha A^\beta - A^\alpha\partial^\beta A_0]. \tag{12}$$

We thus find that

$$cP^\alpha = \rho A^\alpha + \partial_\beta V^{\beta\alpha}; \quad V^{\beta\alpha} \equiv \frac{1}{4\pi}[A_0\partial^\alpha A^\beta - A^\alpha\partial^\beta A_0] \tag{13}$$

which proves the equivalence between the two expressions for electromagnetic momentum density ($c\mathbf{P}$ and $\rho\mathbf{A}$) when used in integrals over all space, provided the second term vanishes sufficiently fast. For the case we are discussing, this is indeed true.

Address for Correspondence

T Padmanabhan
 IUCAA, Post Bag 4
 Pune University
 Campus
 Ganeshkhind
 Pune 411 007, India.
 Email:
 paddy@iucaa.ernet.in
 nabhan@iucaa.ernet.in

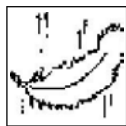

“Scientific reasoning does not differ from ordinary everyday thinking in kind, but merely in degree of refinement and accuracy, more or less as the performance of the microscope differs from that of the naked eye.”

“To be sure, when the pioneer in science sends forth the groping feelers of his thoughts, he must have a vivid intuitive imagination, for new ideas are not generated by deduction, but by an artistically creative imagination.”

– Max Planck

